

# CHROME

## Kolejność montażu brył *Dotyczy wszystkich wariantów*

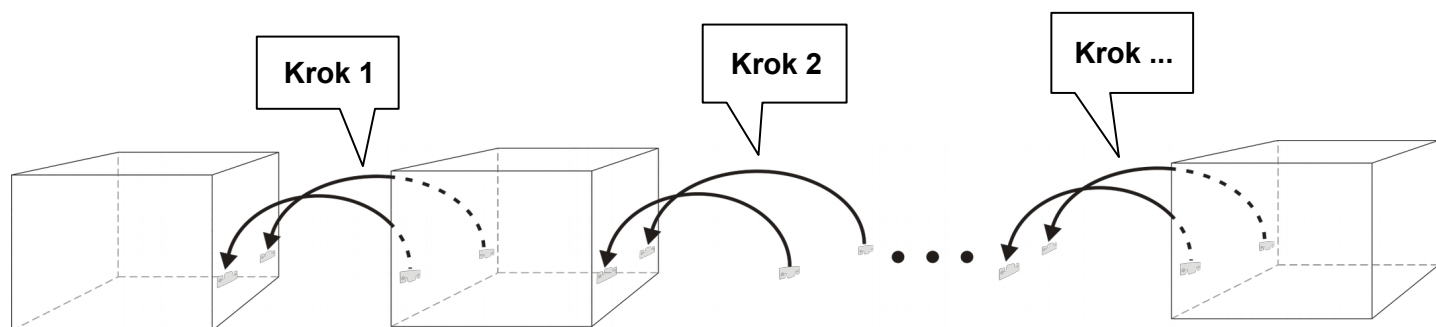

## Przykładowy wariant *CHROME OTL-2F-E-2SR*

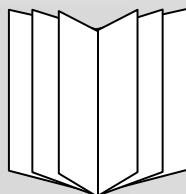
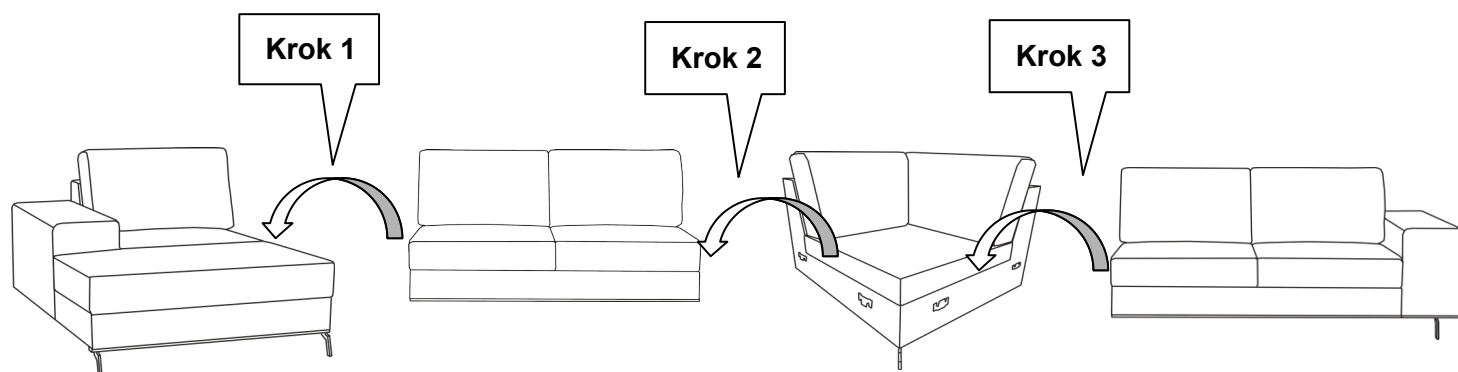
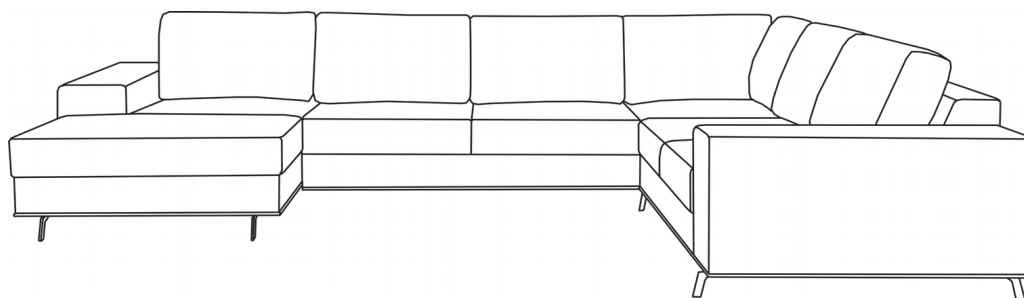

PZ2

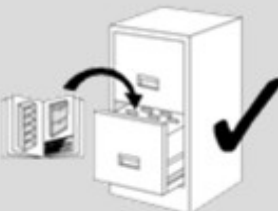

# CHROME

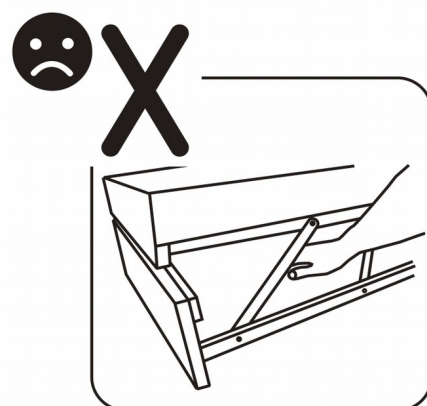
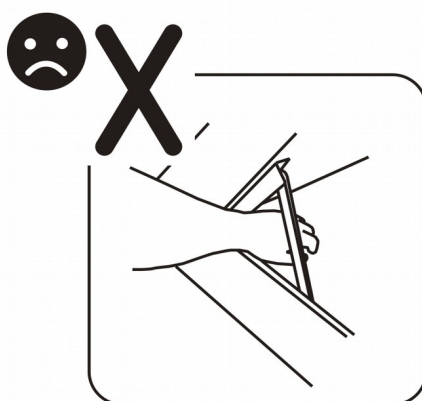
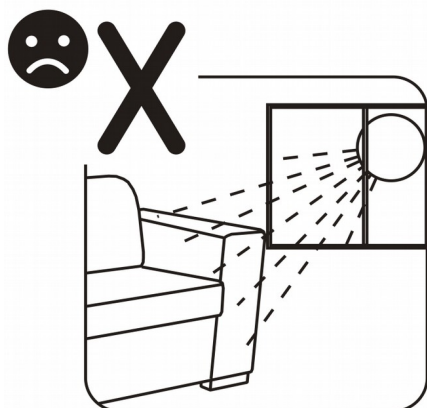
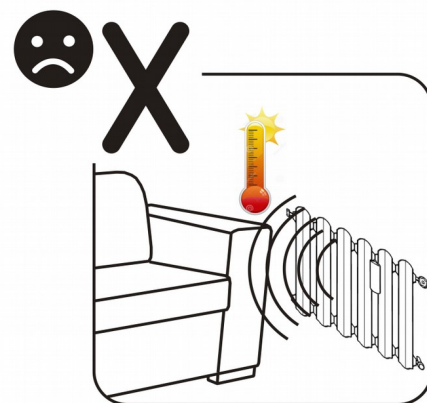
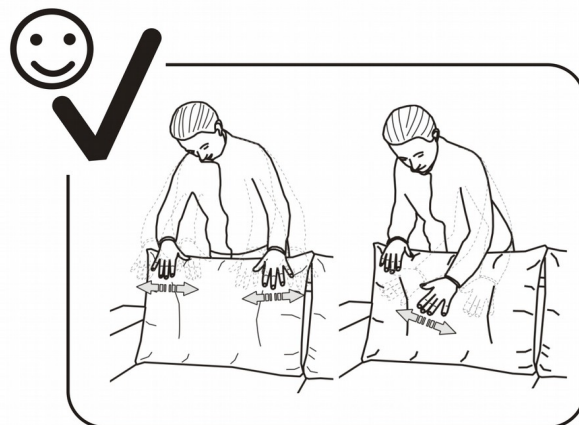

# CHROME 1, 1.5



x4



x1

A

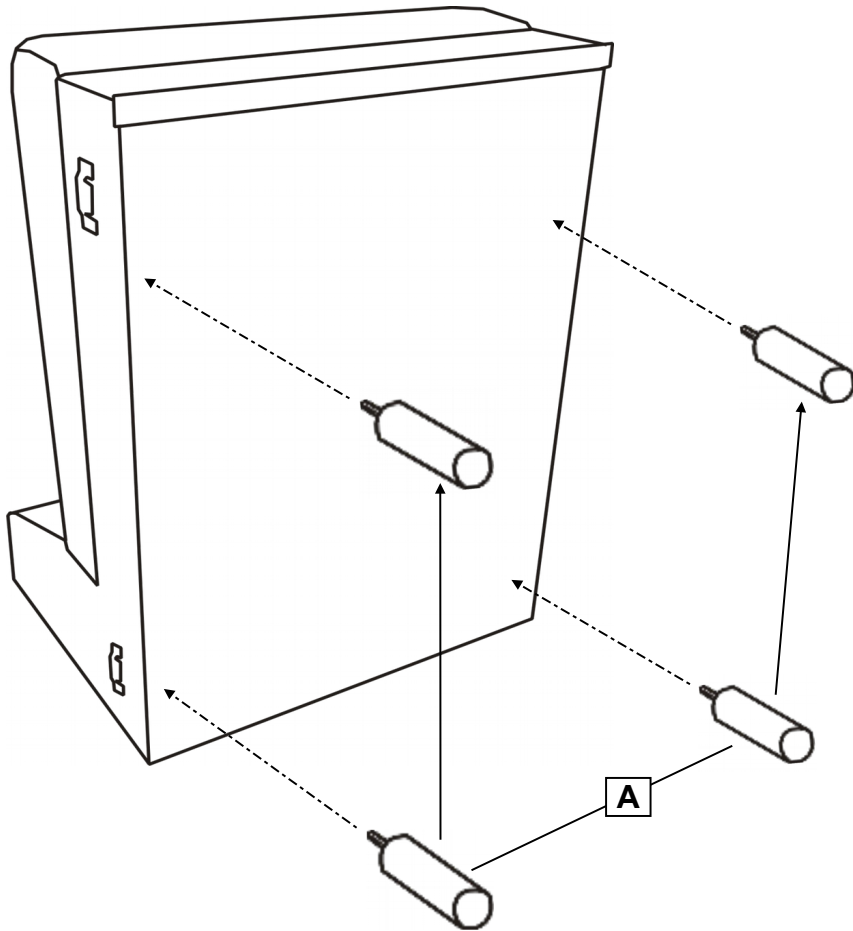

# CHROME 1SL, 1SwL, 1.5SL, 1.5SwL

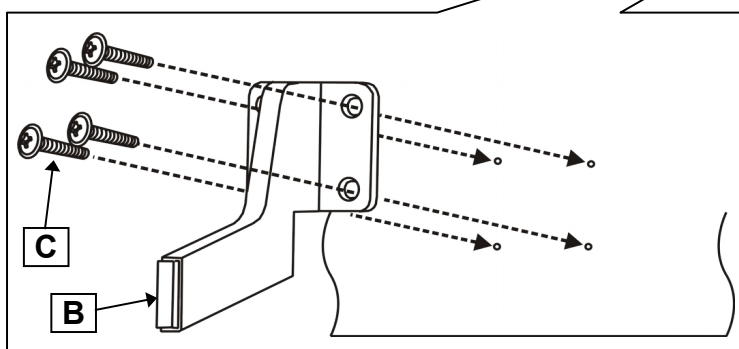
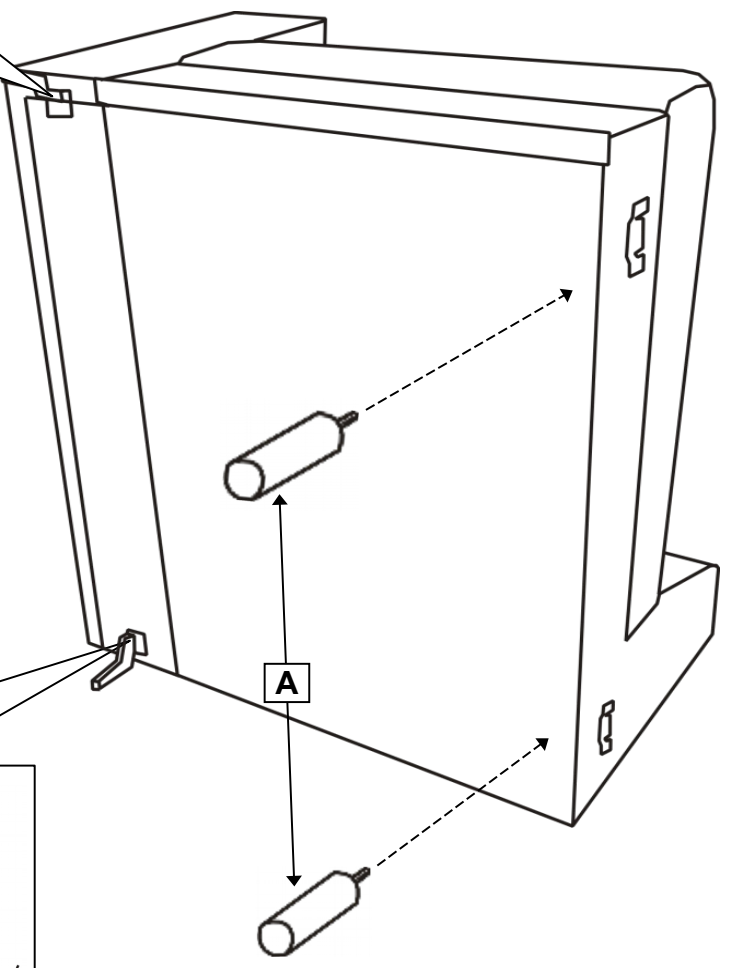
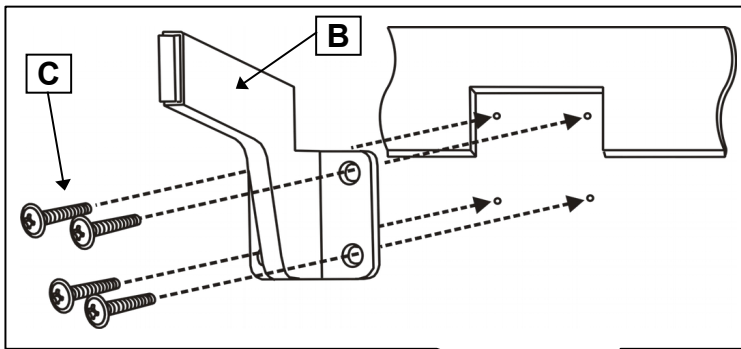
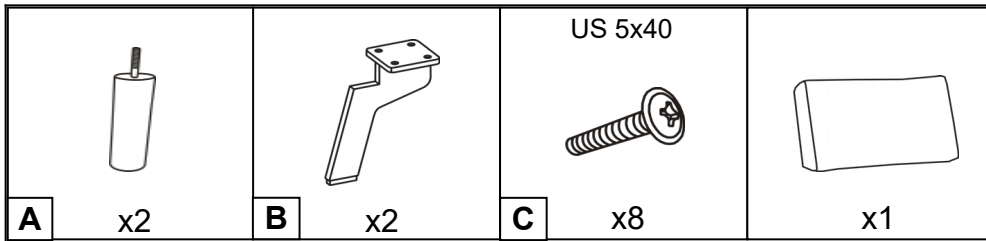

# CHROME 1SR, 1SwR, 1.5SR, 1.5SwR

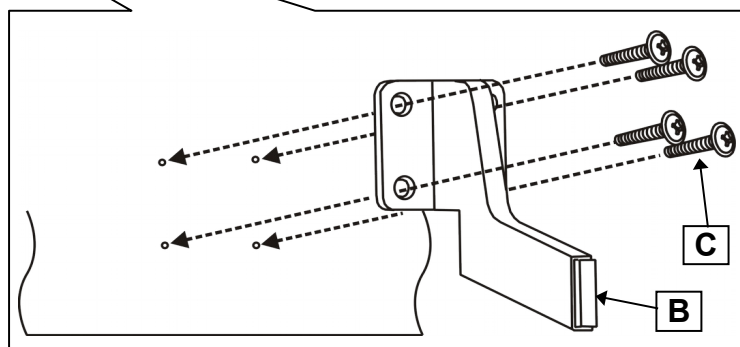
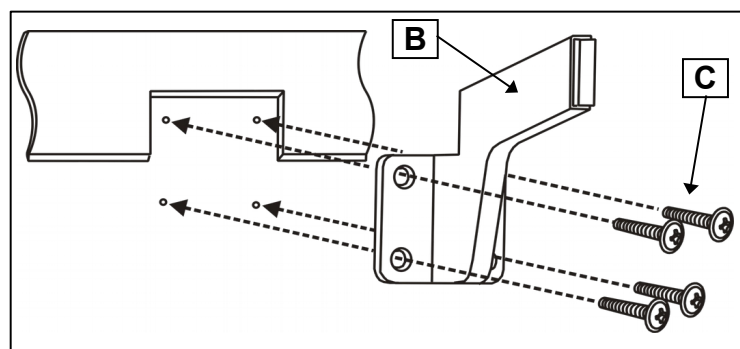
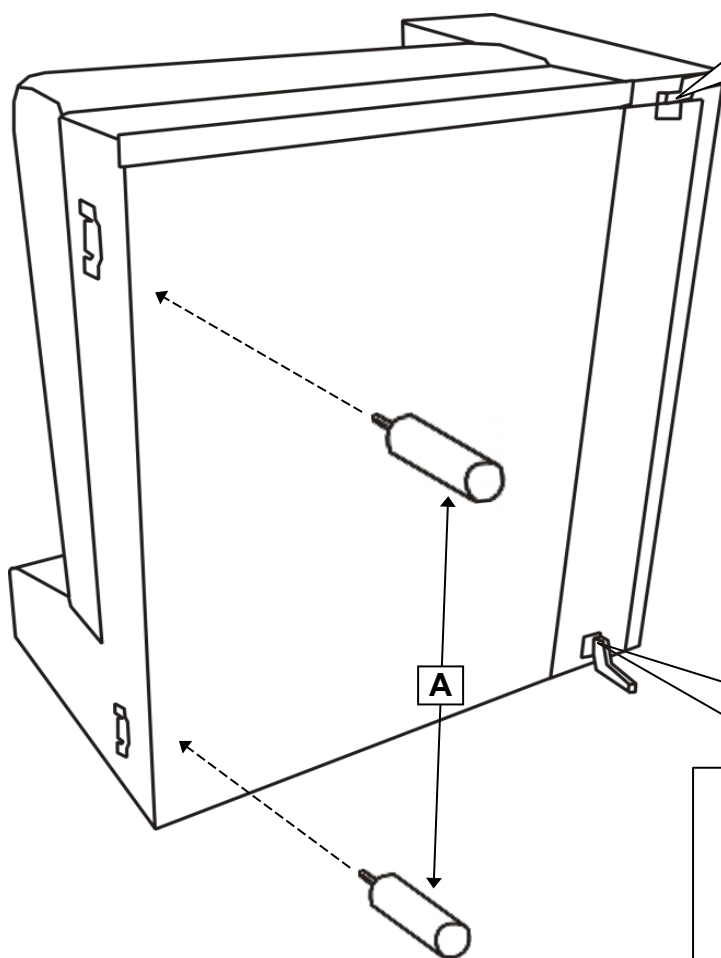
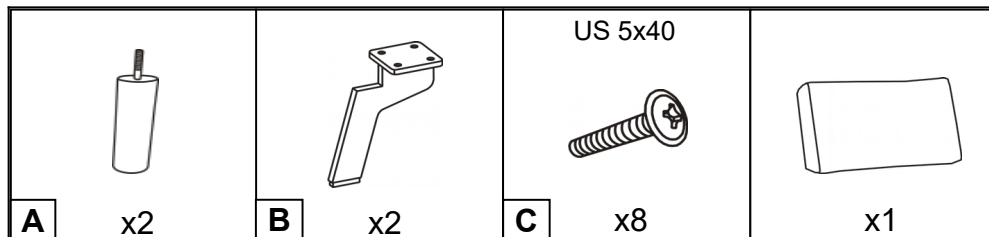

# CHROME 1S, 1Sw

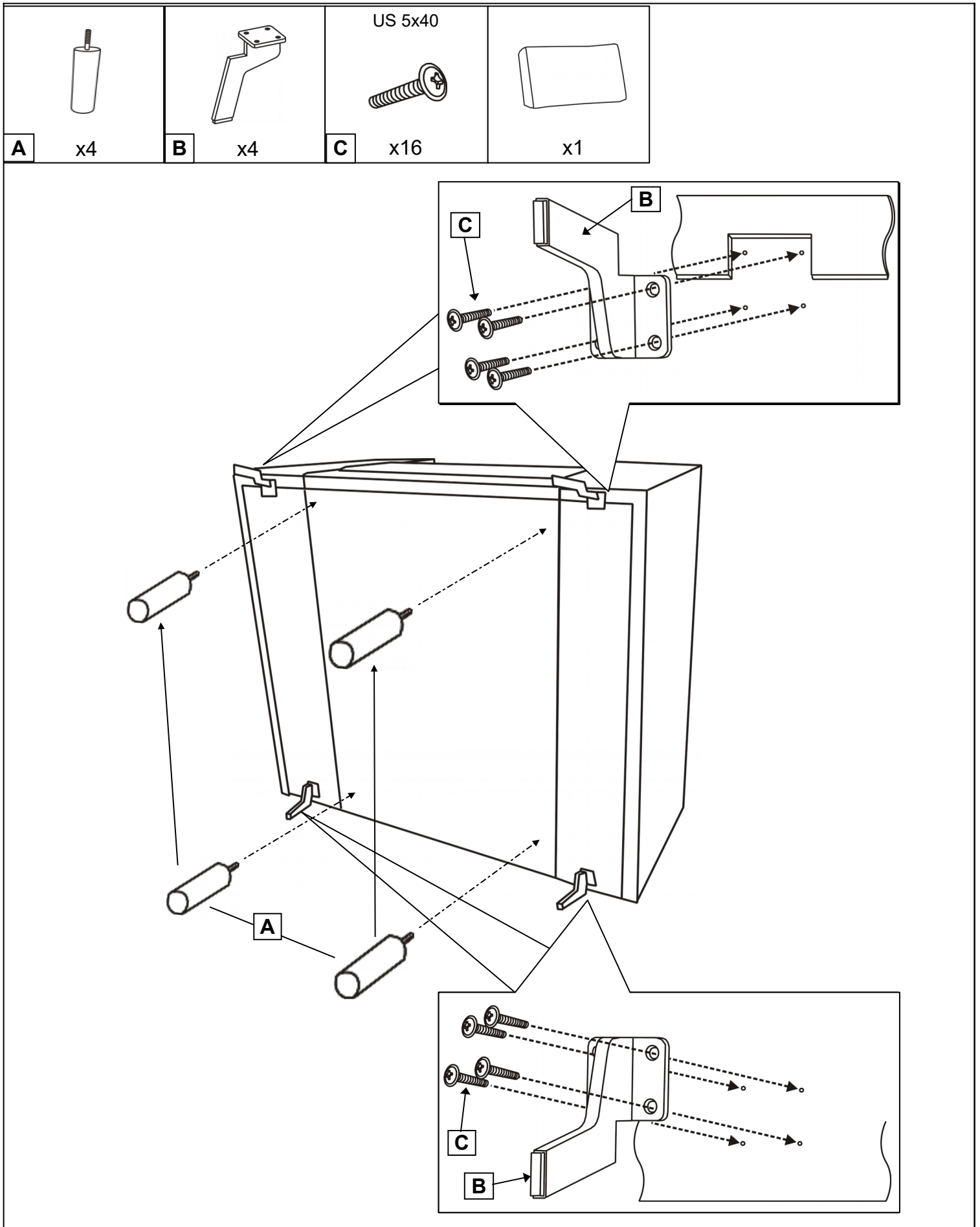

# CHROME 2, 2.5, 2BK



x4

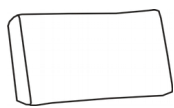

x2

A

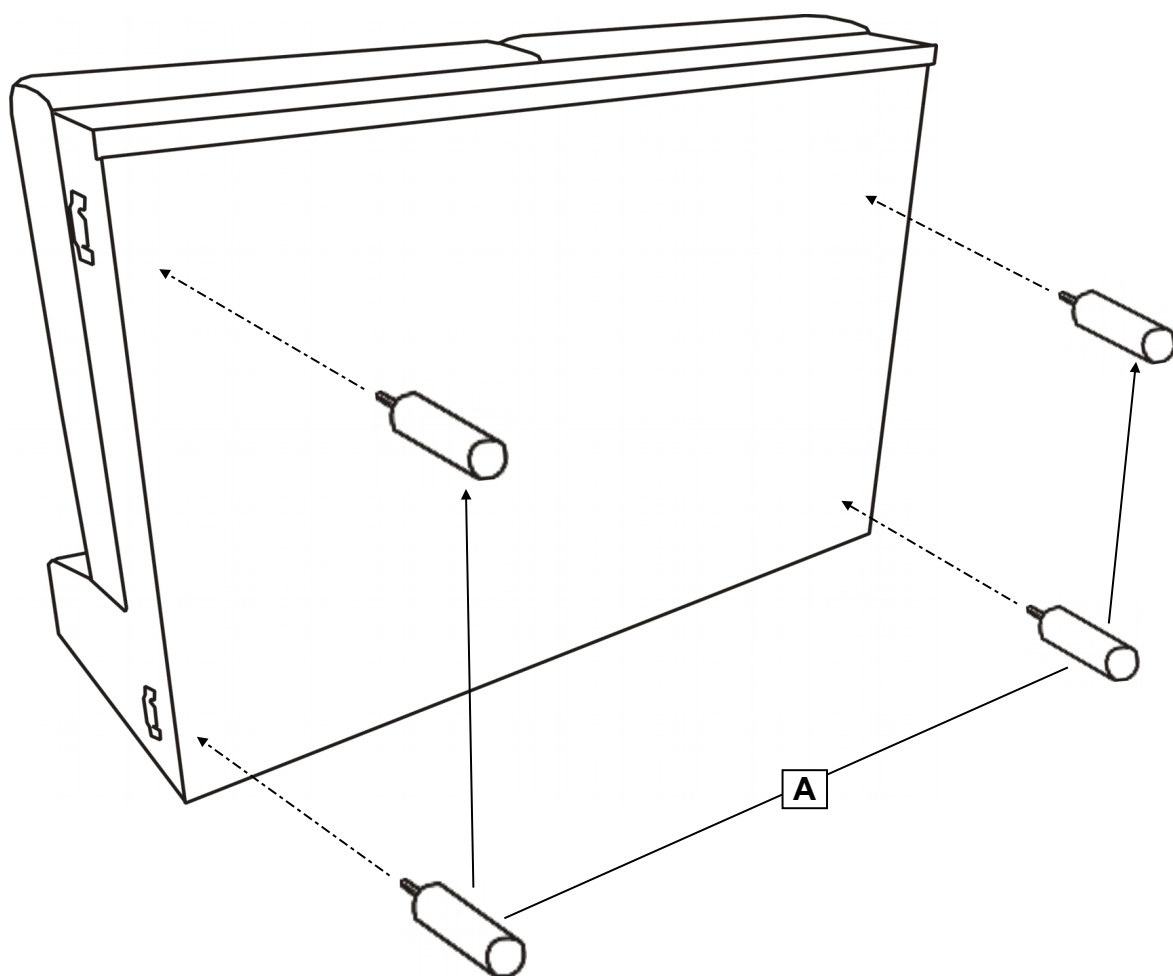

# CHROME 2S, 2.5S, 2Sw, 2.5Sw, 2SBK, 2SBKw

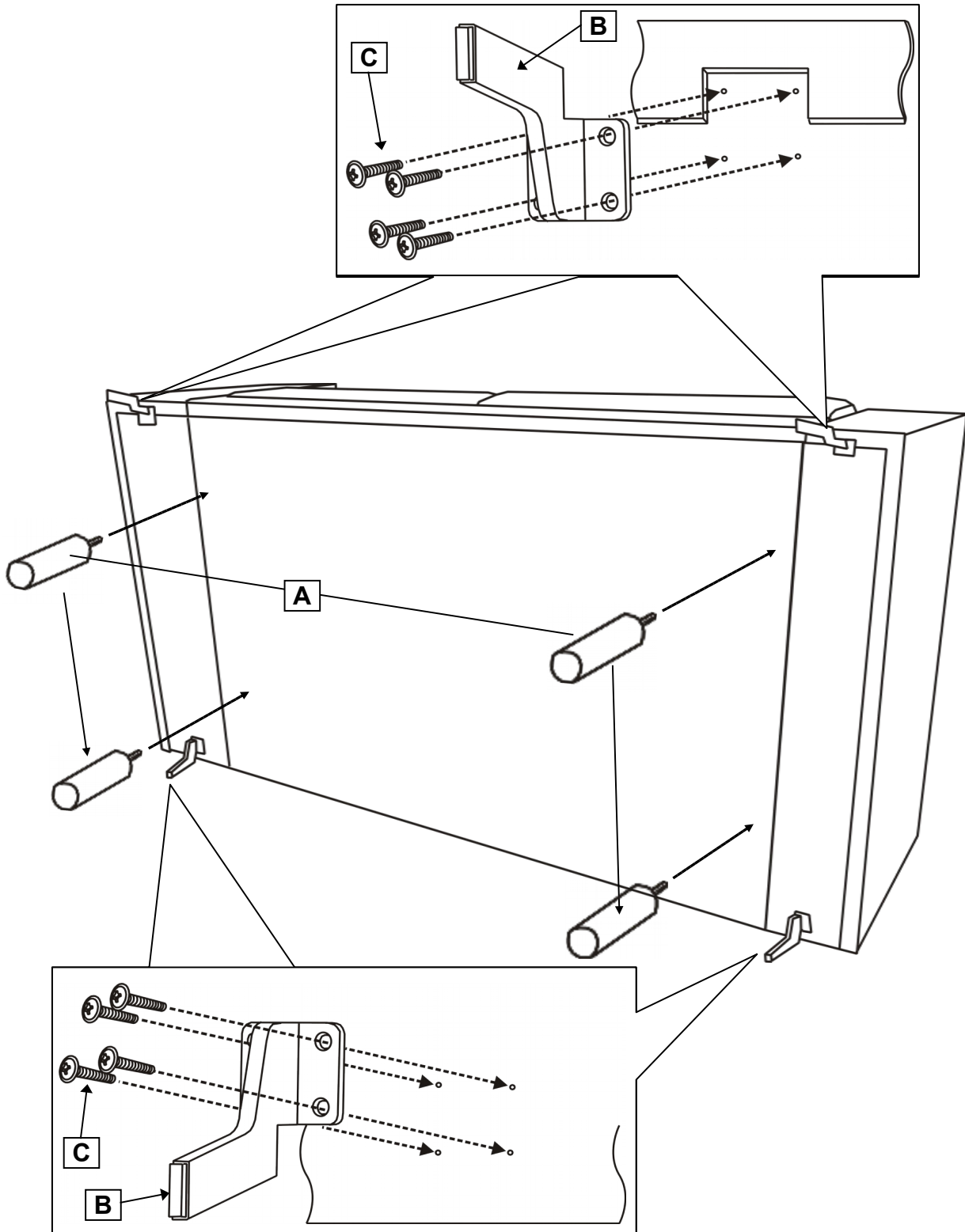
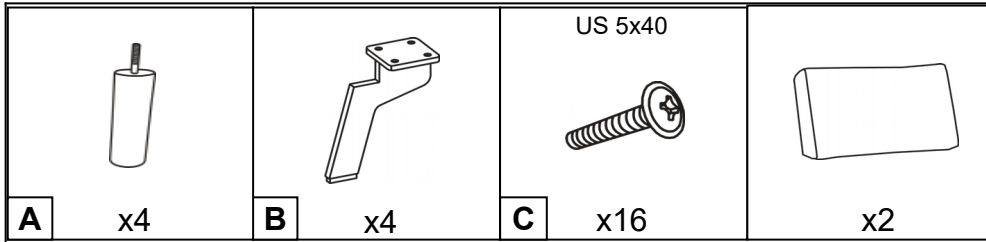



# CHROME 2SL, 2SwL, 2.5SL, 2.5SwL, 2BKL, 2BKwL

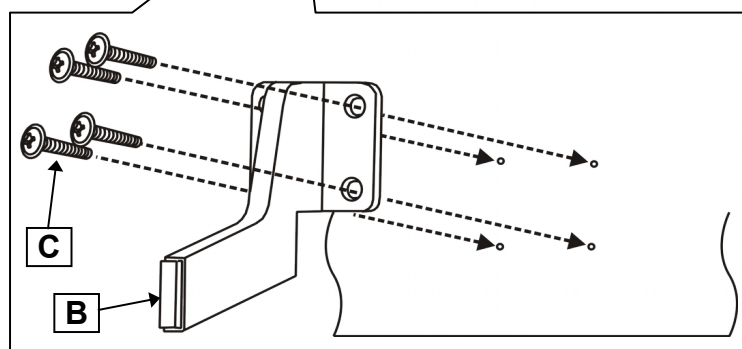
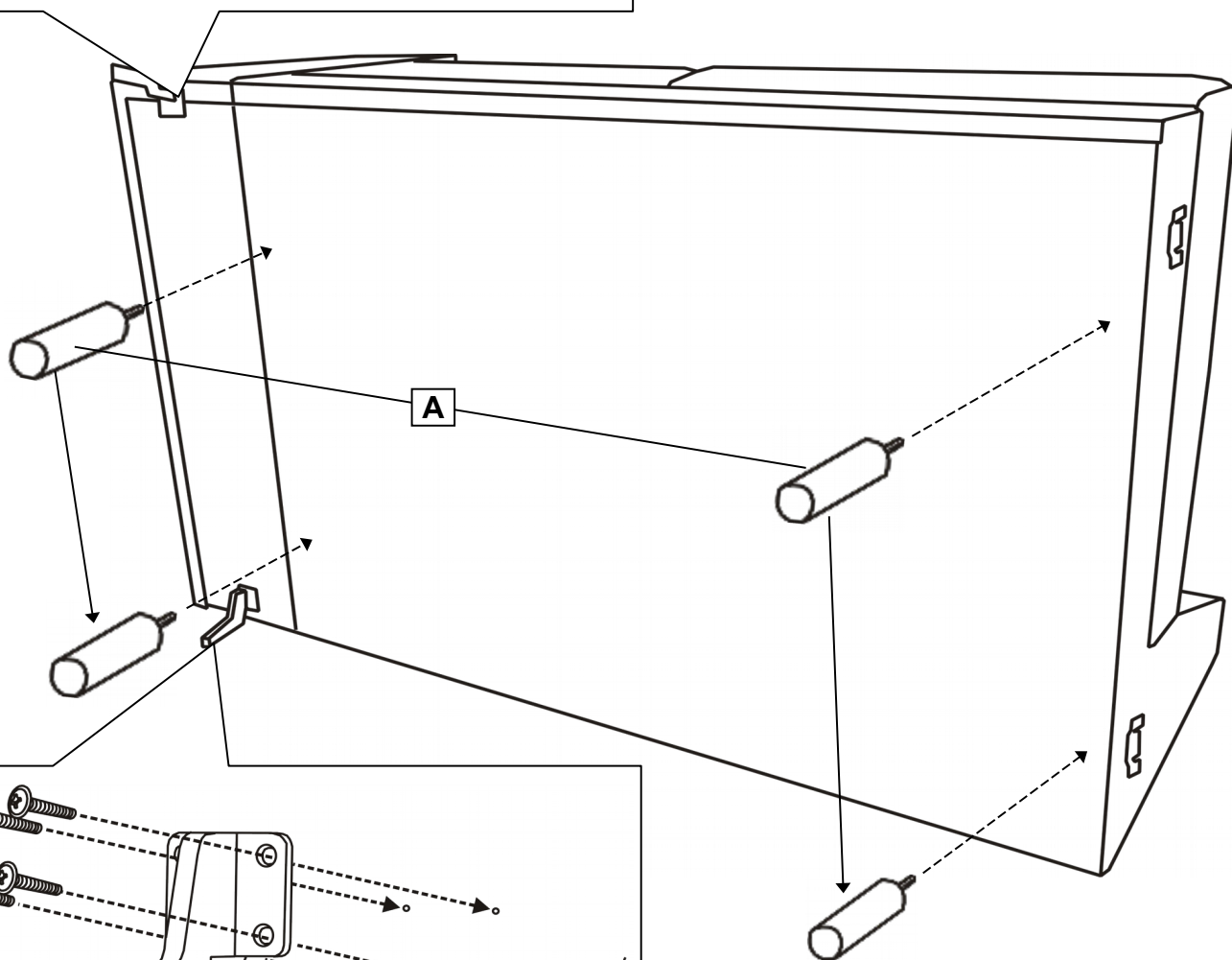
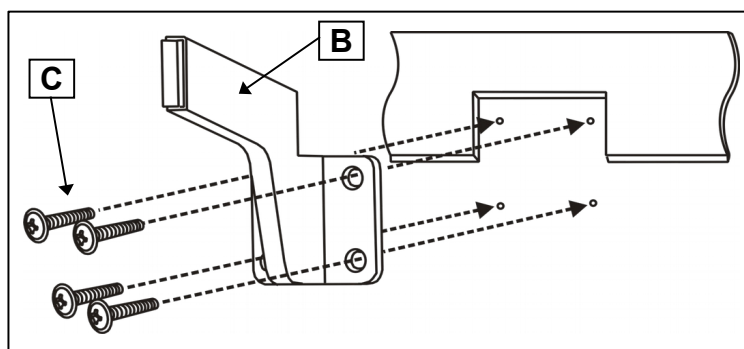
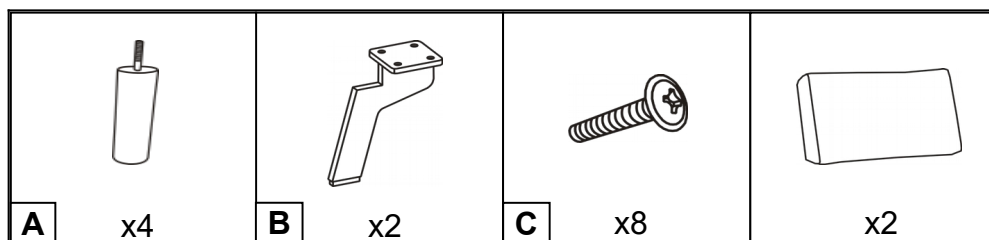

# CHROME 2SR, 2SwR, 2.5SR, 2.5SwR, 2BKR, 2BKwR

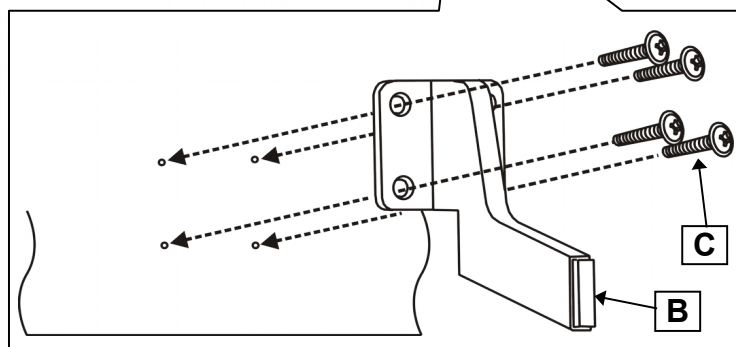
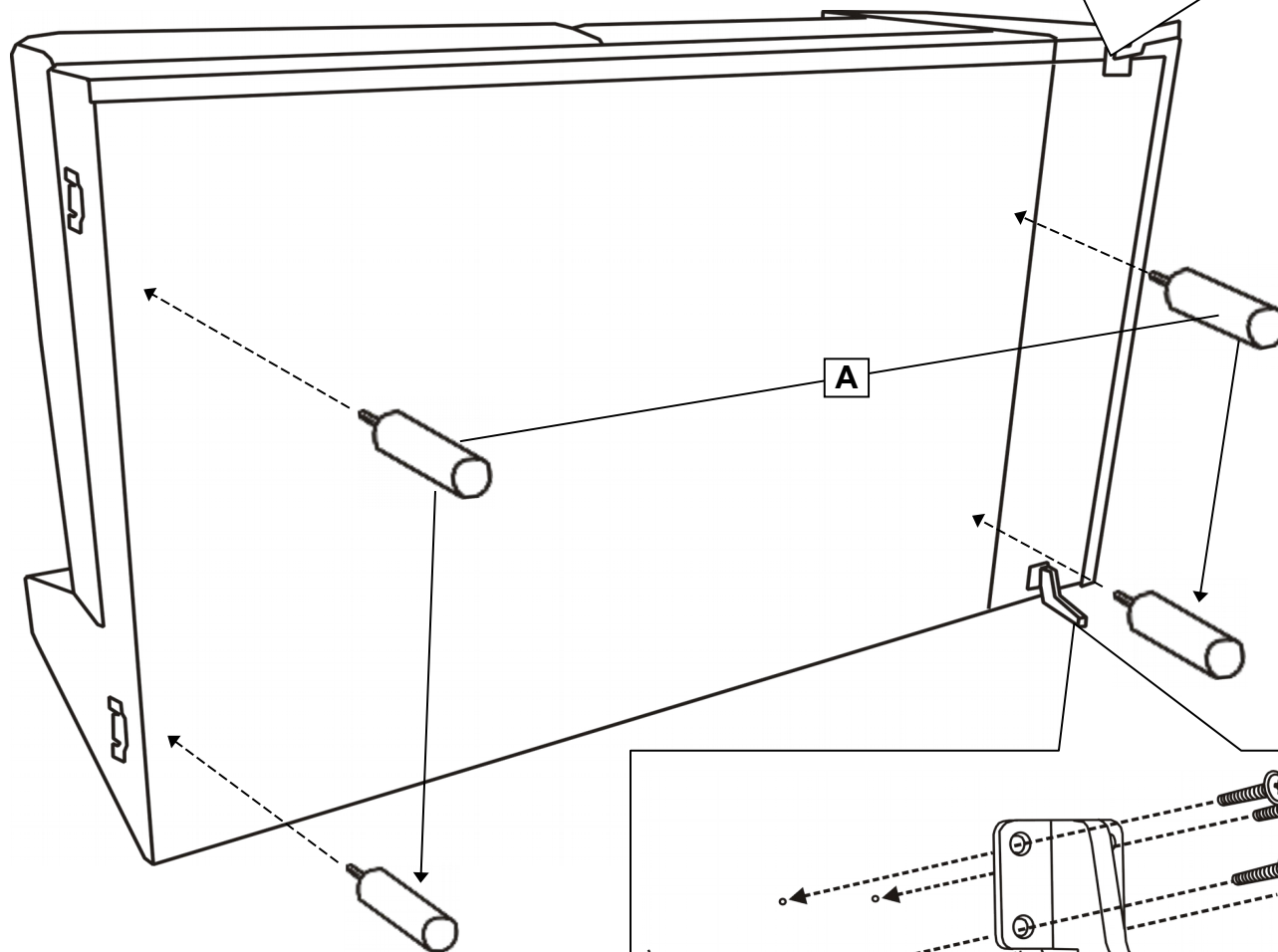
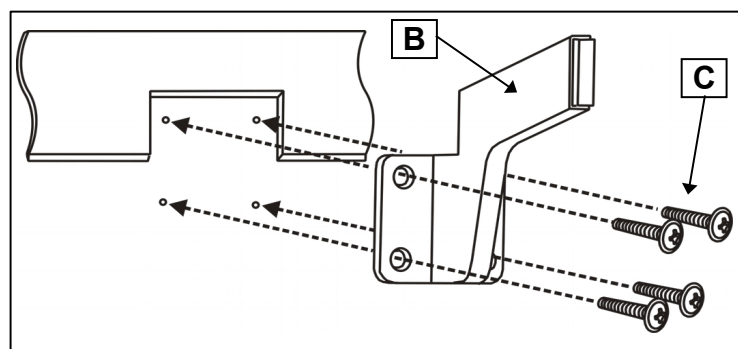
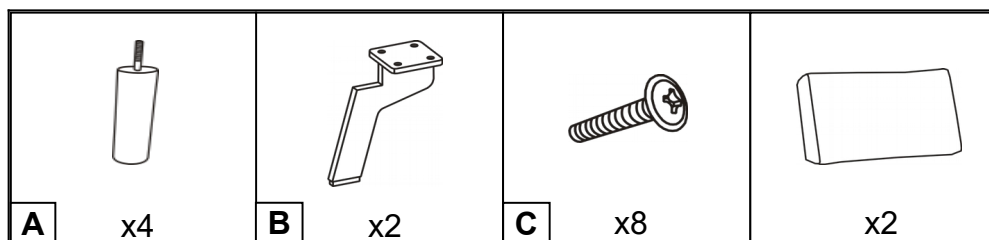

# CHROME 2F

US 5x40



**C**

x4



**D**

x4

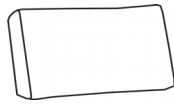

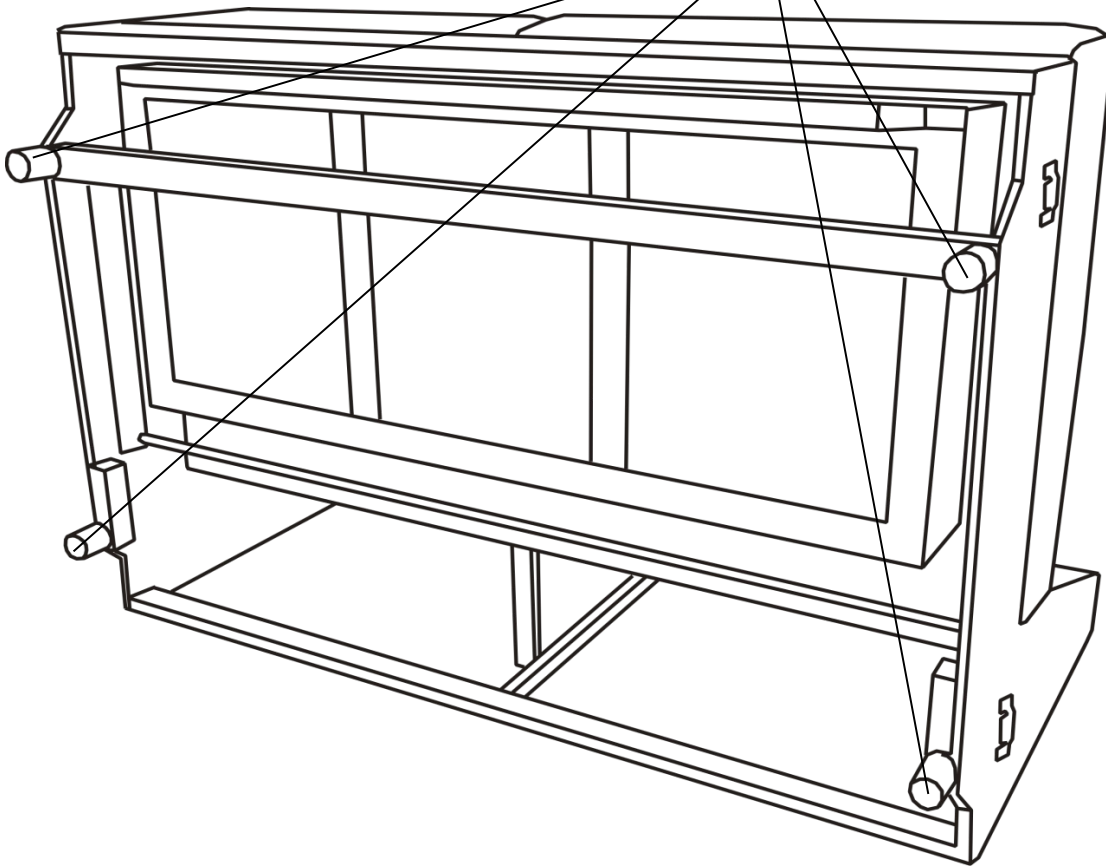
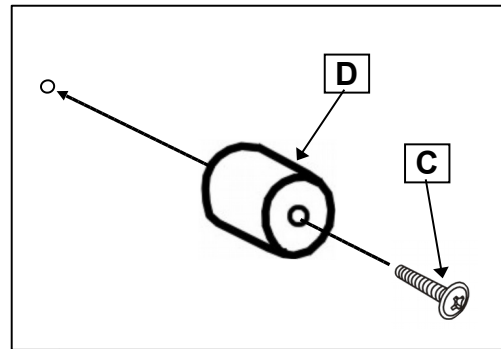

x2

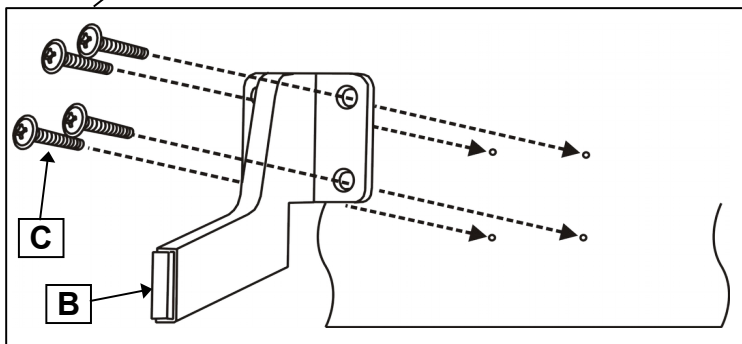
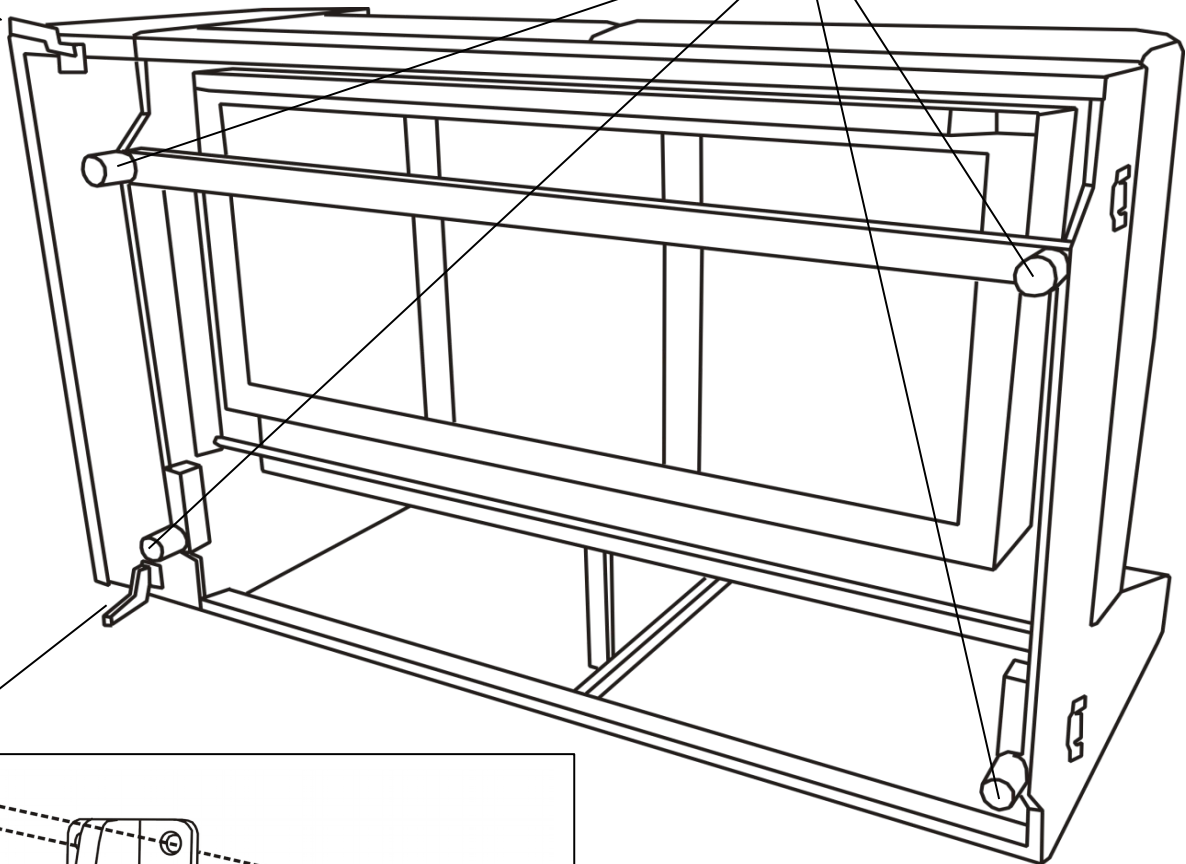
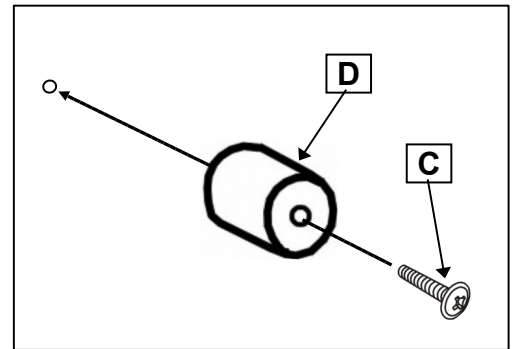
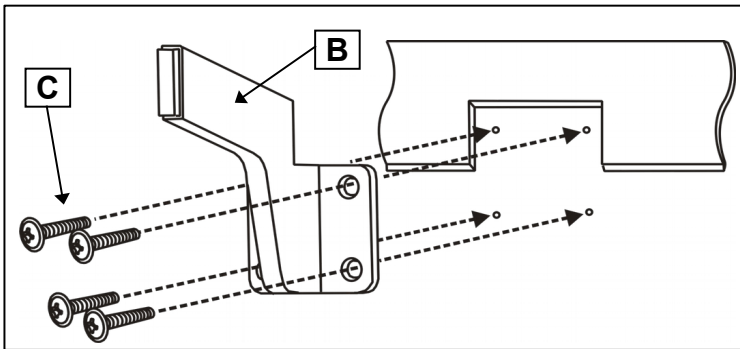
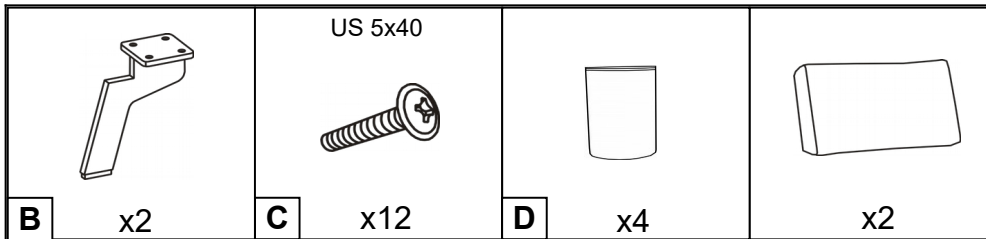

# CHROME 2FL, 2FwL



# CHROME 2FR, 2FwR

	US 5x40		
<b>B</b> x2	<b>C</b> x12	<b>D</b> x4	x2

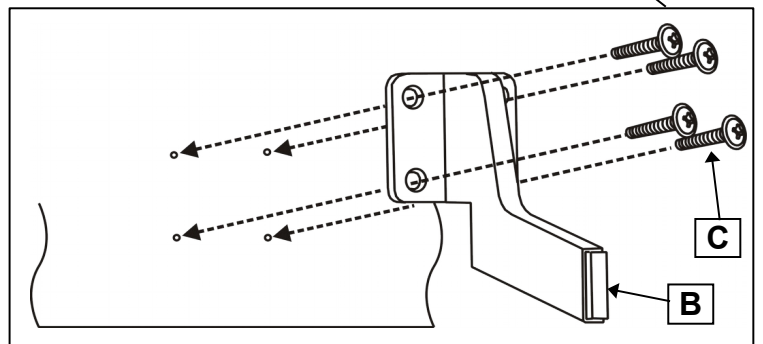
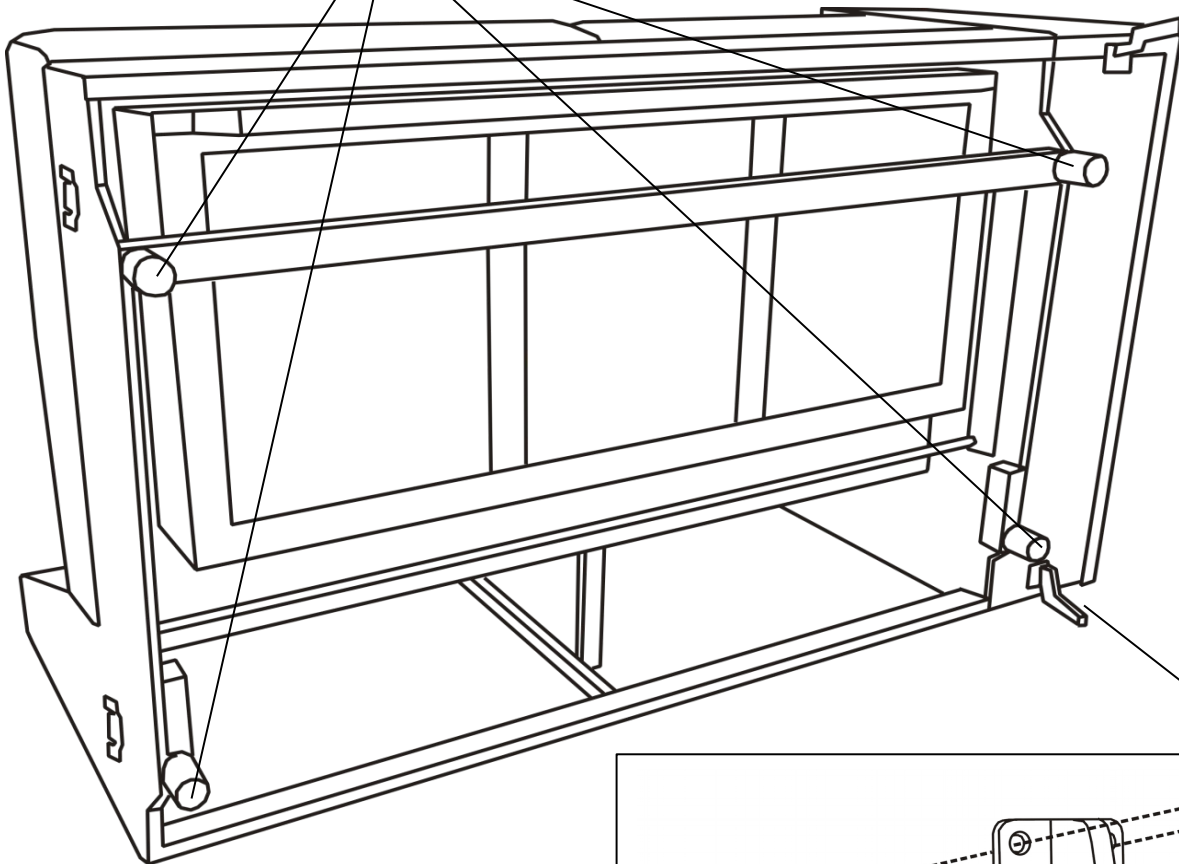
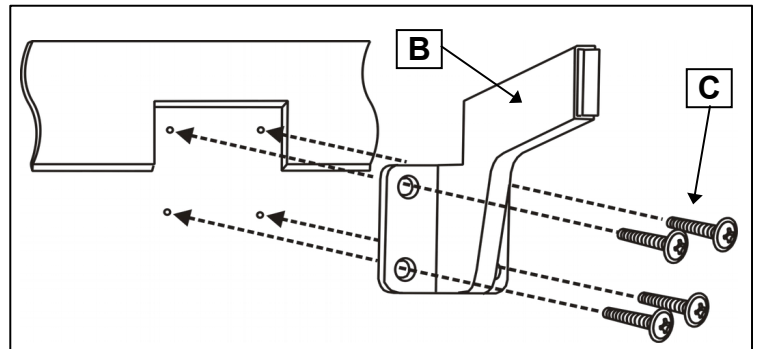
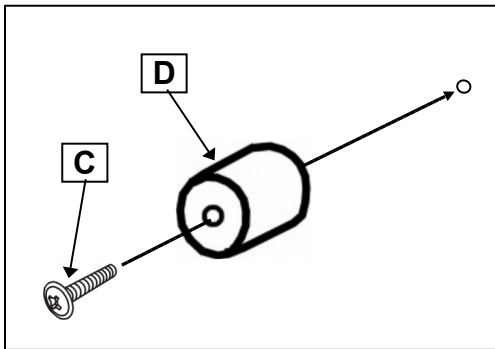

# CHROME E

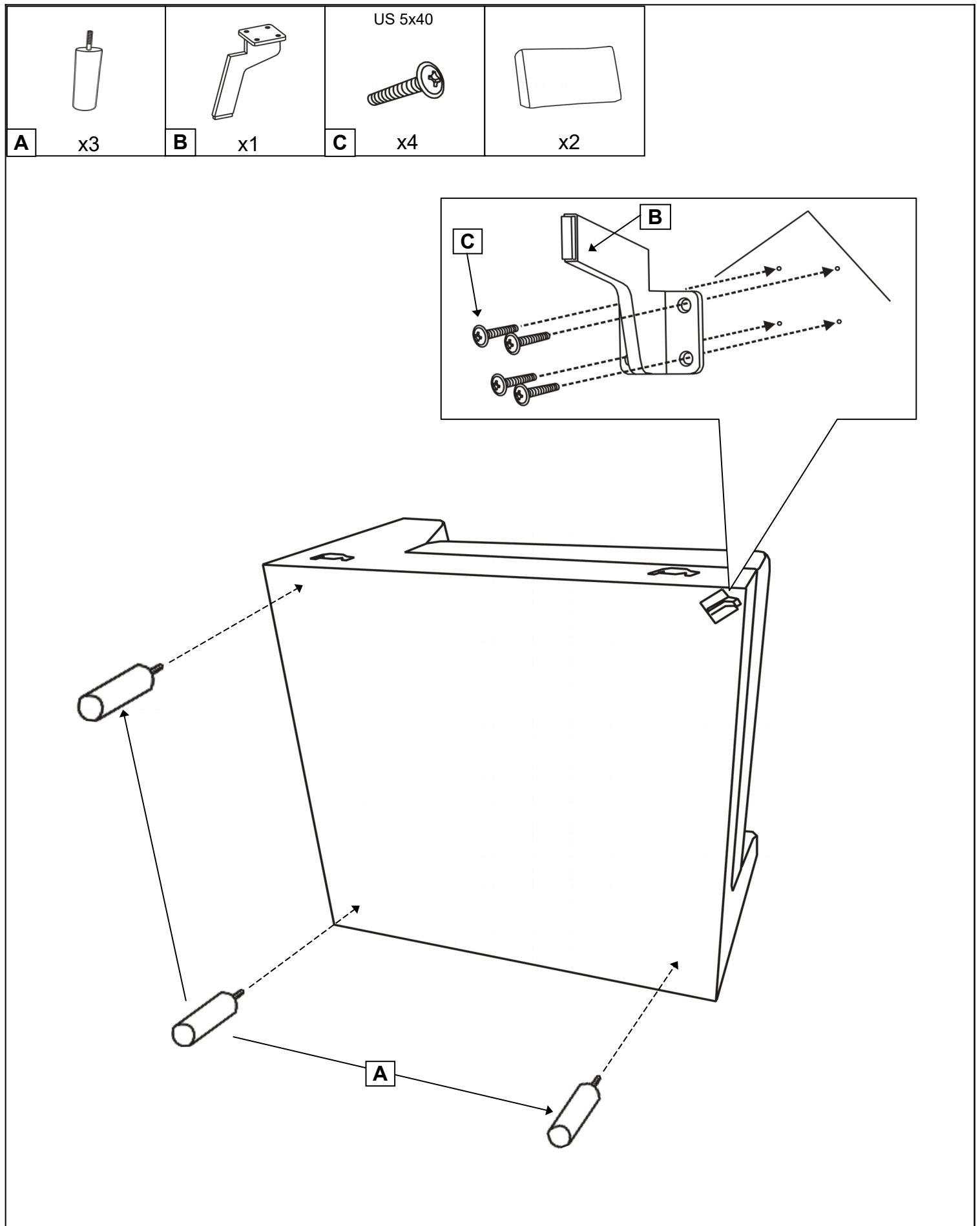

# CHROME OBKL, OBKwL

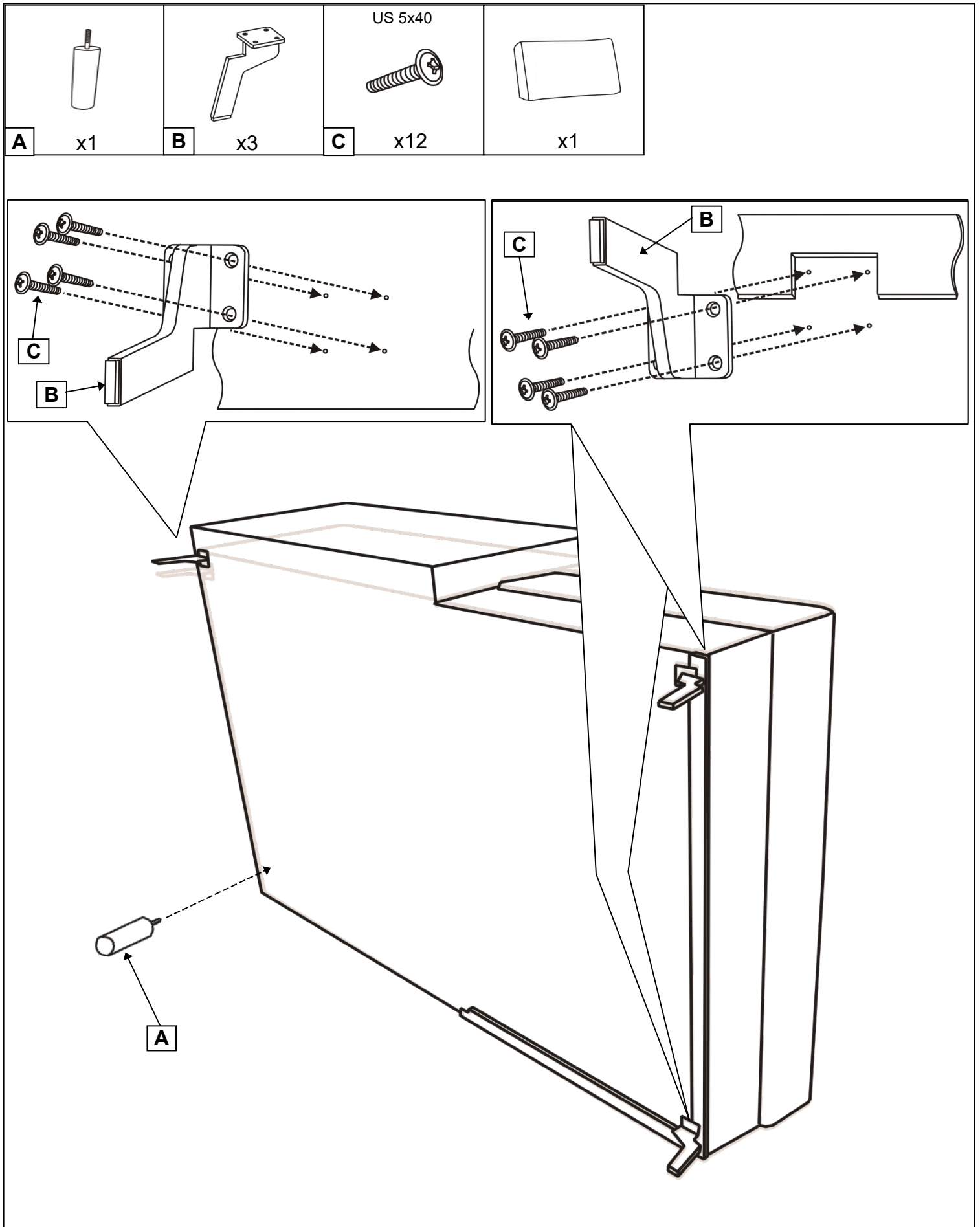



# CHROME OBKR, OBKwR

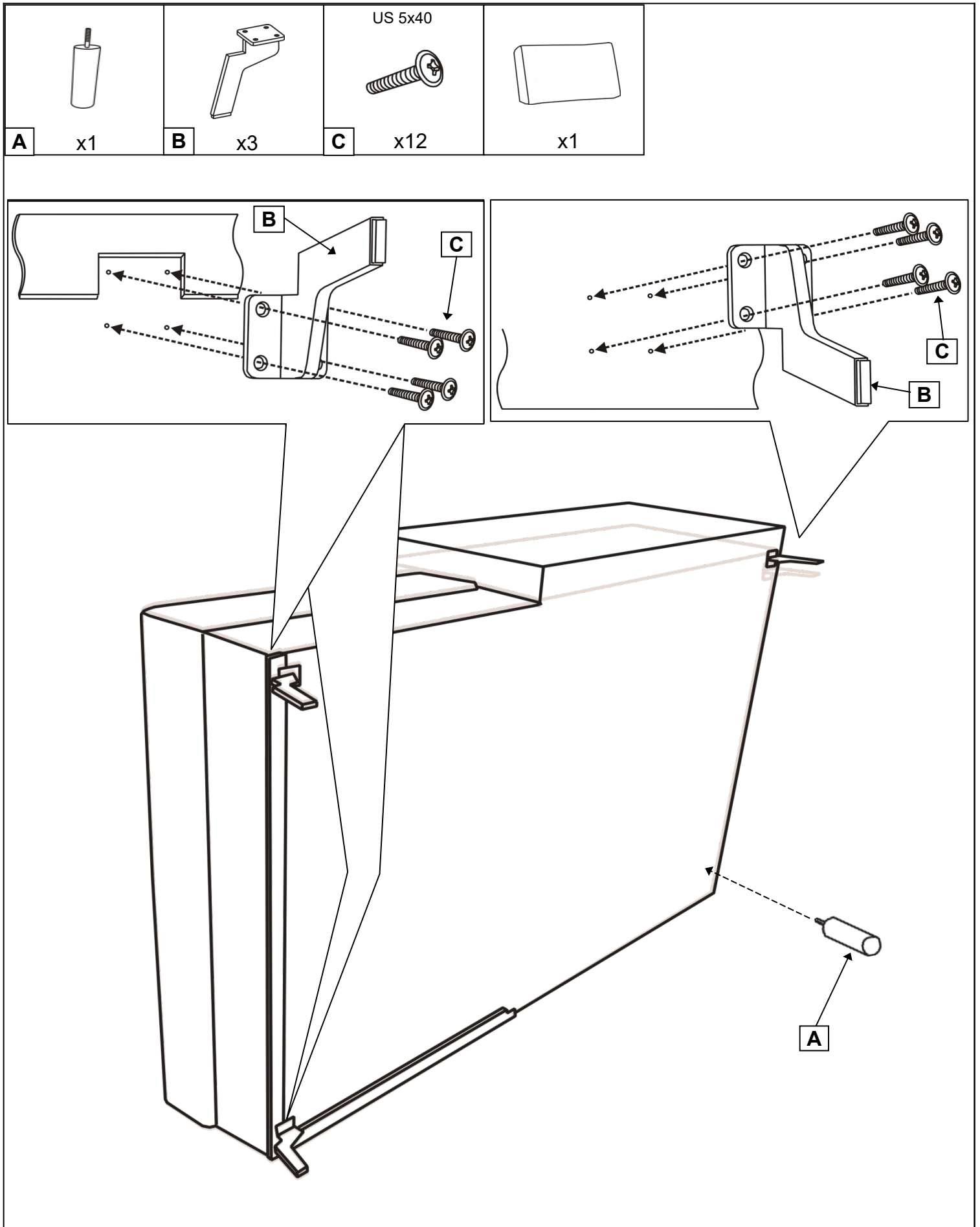



# CHROME HO75, HO110

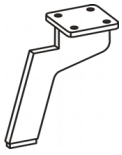

**B** x4

US 5x40



**C** x16

**4x**

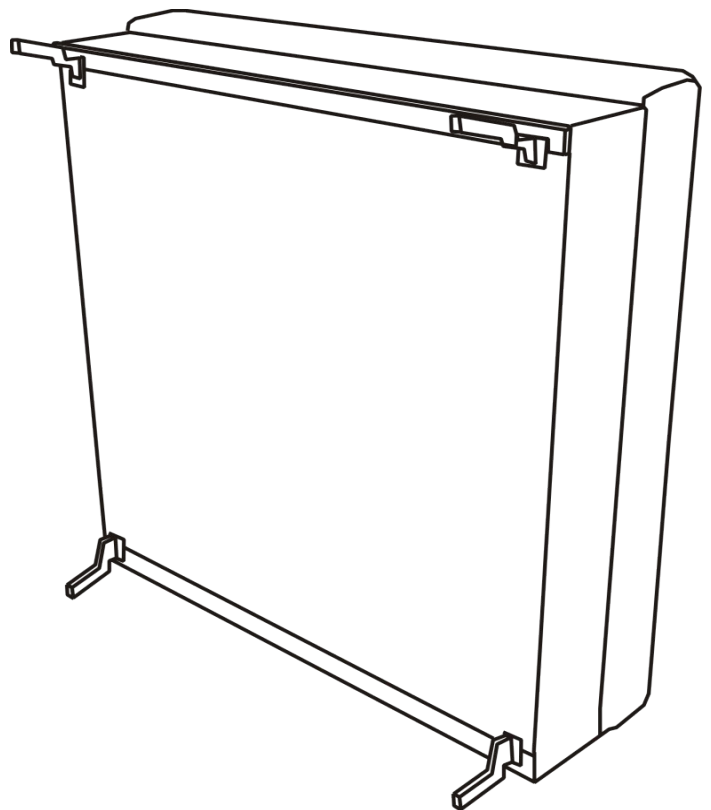
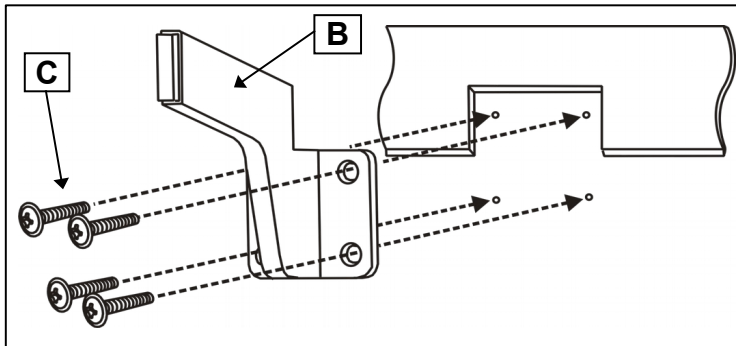

# CHROME HO75L, HO110L

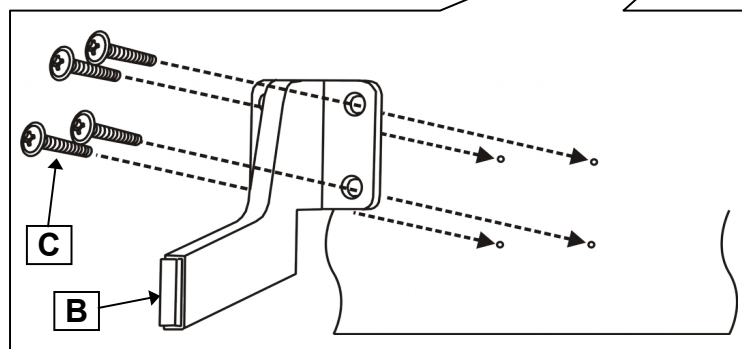
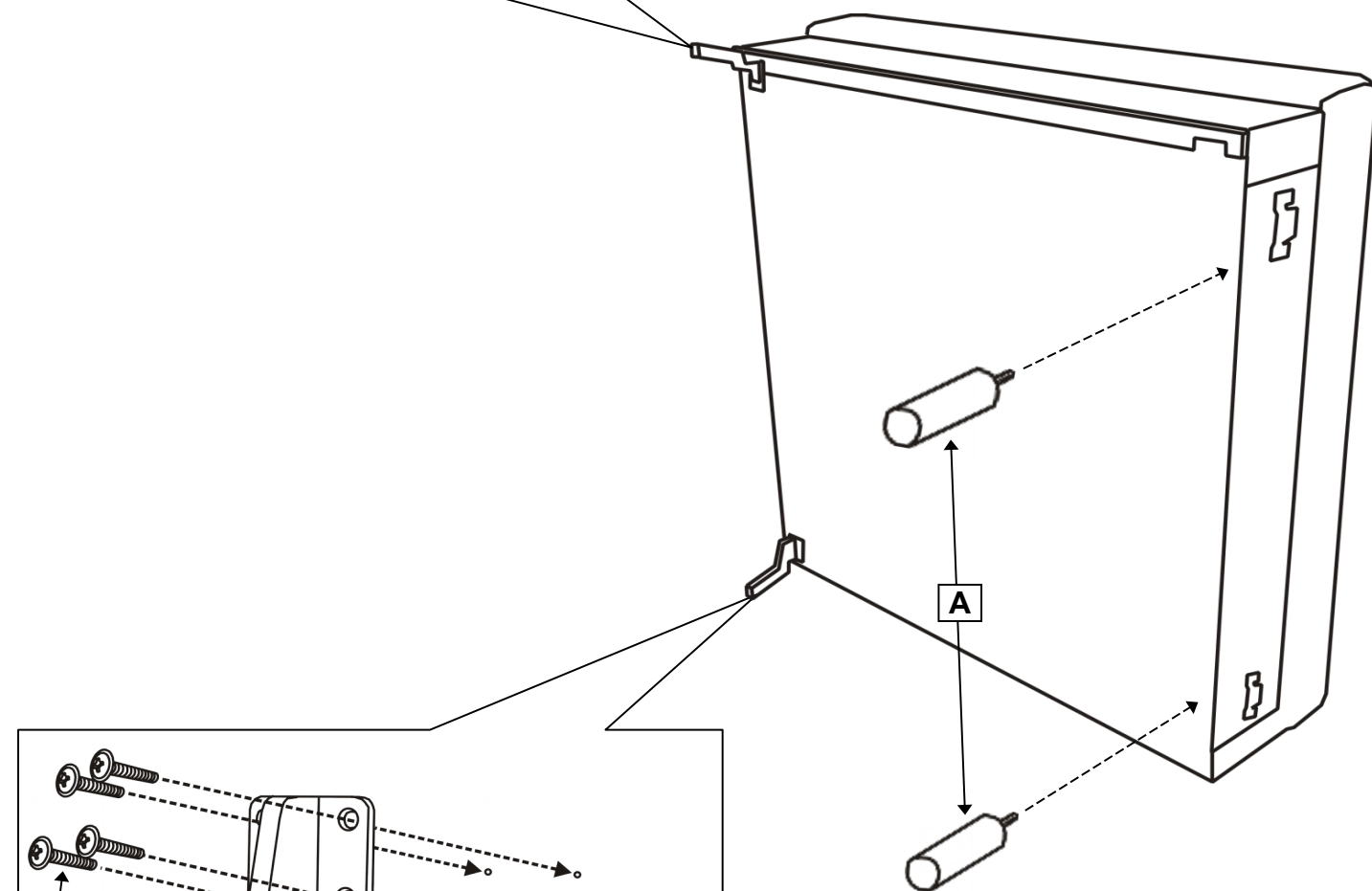
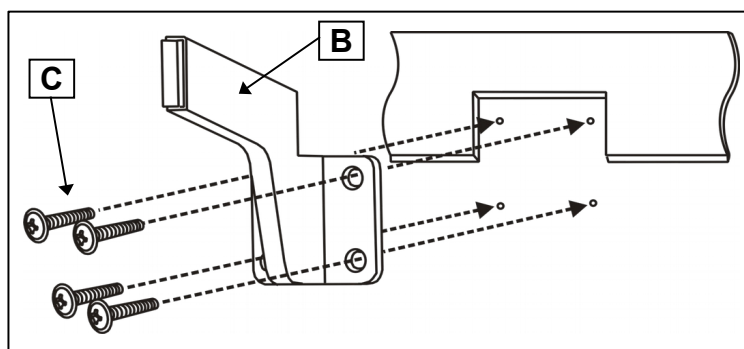
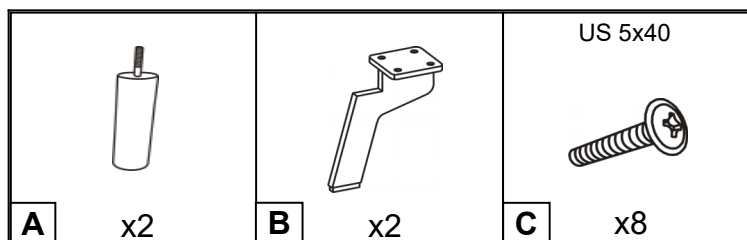

# CHROME HO75R, HO110R

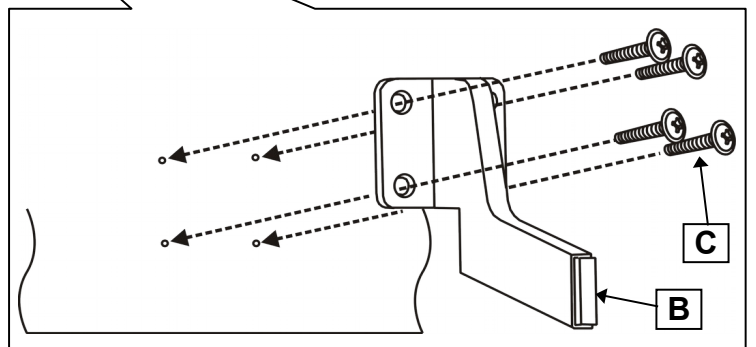
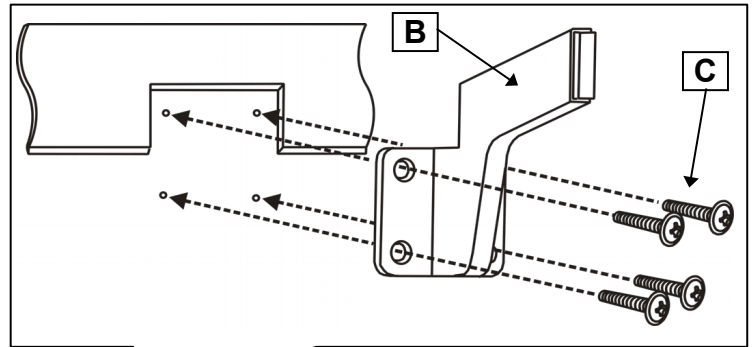
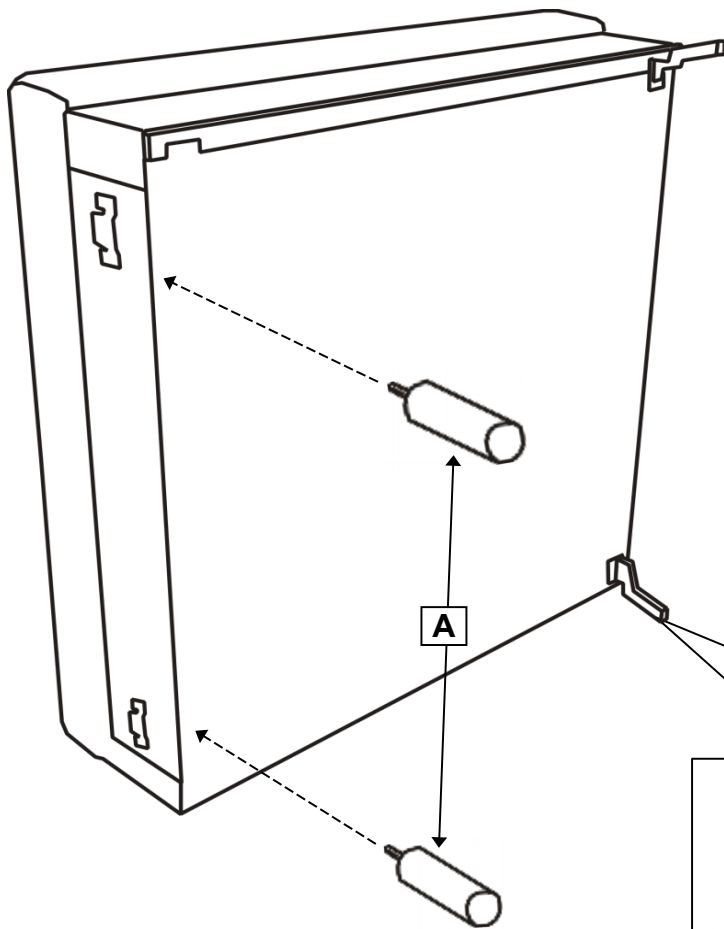
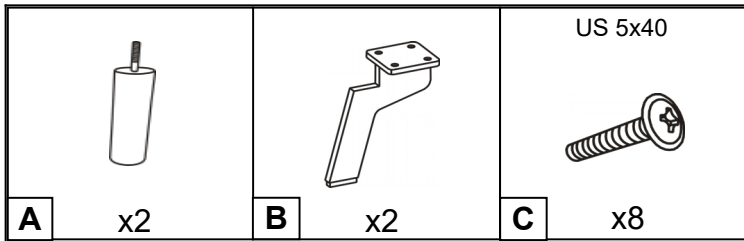

# CHROME HO75R, HO110R



A

x4

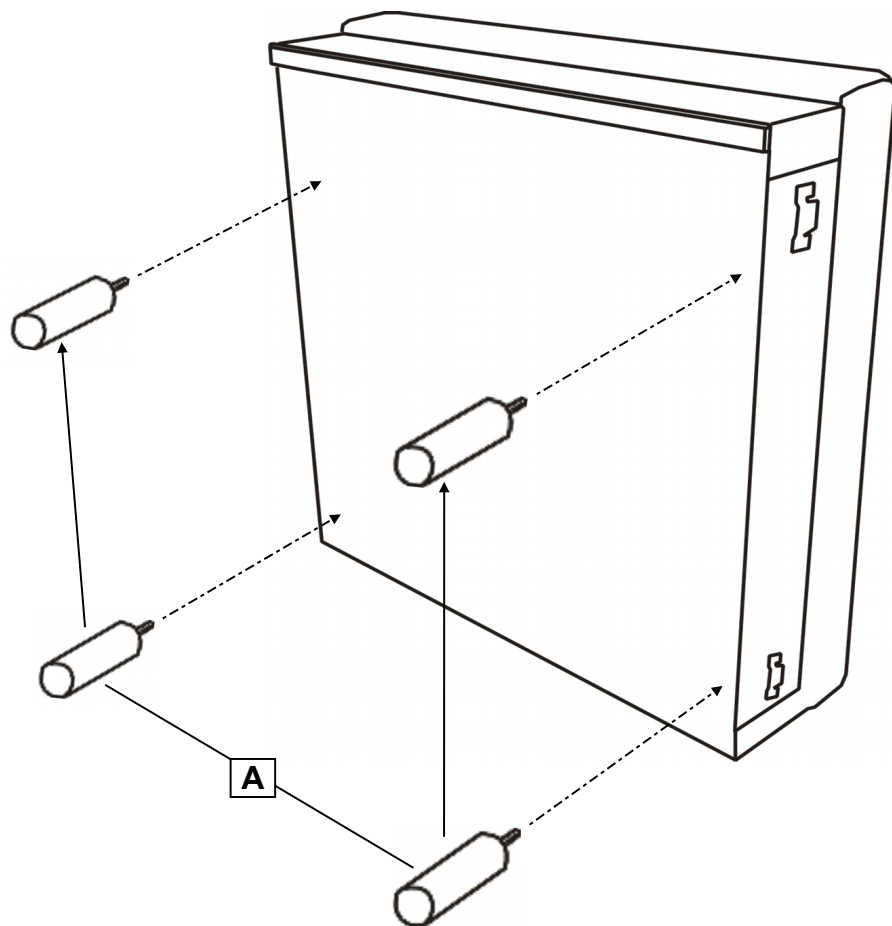

# CHROME PKL, PKwL

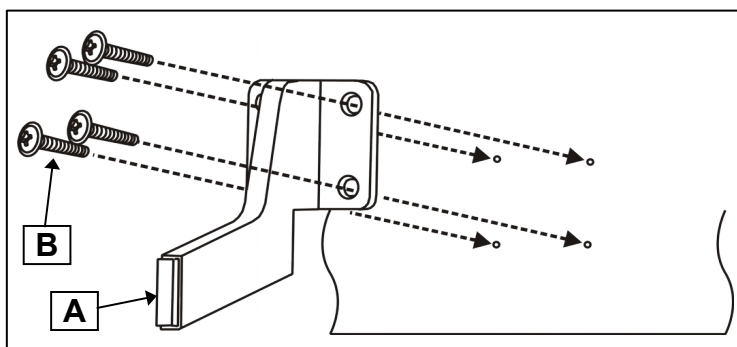
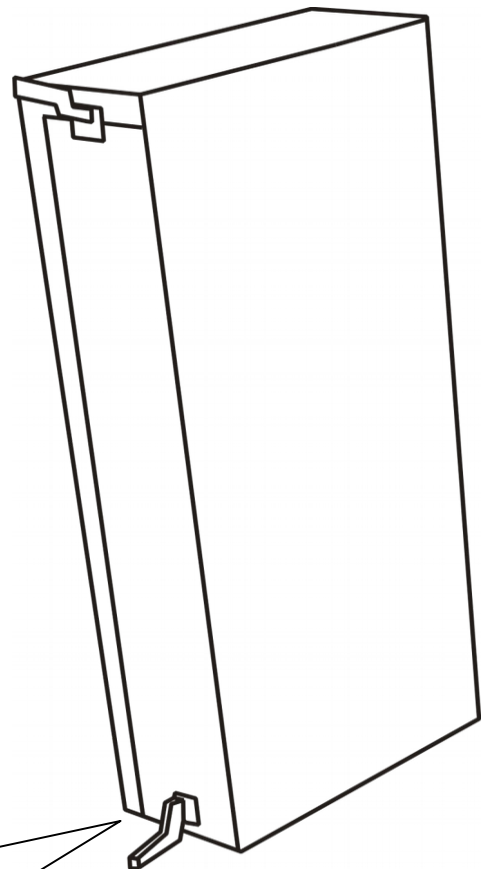
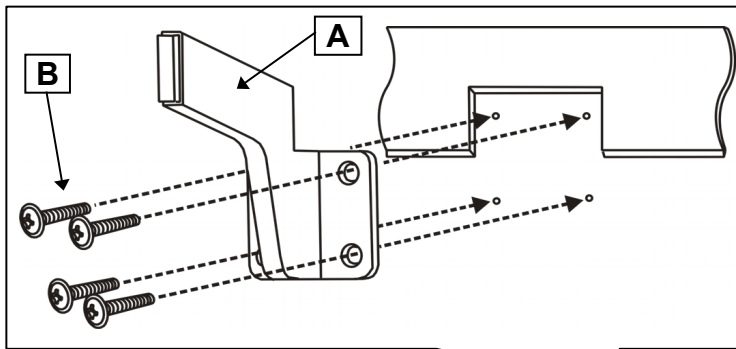
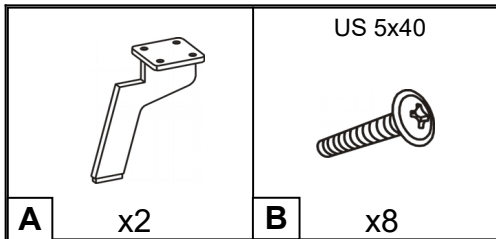

# CHROME PKR, PKwR

